

KGK JET CHECKER PK010

Lightweight and Compact, All-in-one Print Inspection System for detection of printing failures of inkjet printers

カタログ No.9123E

<http://www.kishugiken.co.jp/>



NEW

Inspecting Print Quality. KGK JET CHECKER is designed to detect poor print quality and print failures.



■ Easy installation for everyone

A controller, a camera, and a lighting system are integrated into one compact body. Anyone can install the system easily.

■ Simple 3 step setting!

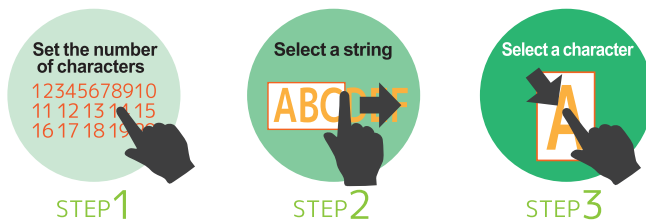

■ Remote control function

You can remotely control the system via wired/wireless LAN by using VNC. This function is useful in the situation where the system is to be monitored and controlled from the management office, or it cannot be directly operated.



■ Access to network storage available

Image data can be stored not only on the local area but also on a network storage area. This enables all inspection image data to be stored, contributing to the improvement of traceability.

■ Automatic positioning function

The system is equipped with the function that automatically calculates inspection positions just by allowing target objects to run through in front of the camera. It makes setting inspection positions easier, and is effective in the situation where it is not possible to let target objects run repeatedly.

■ Synchronization function

The synchronization function connects the system to an inkjet printer. This function helps to reduce not only the input workload but also input errors.



▲Camera; Lights; Controller



▲Operation screen

● Specifications

Item	Specifications
Number of product types that can be registered	Up to 20
Number of cameras	1 unit
Character types to be inspected	Numeric characters, uppercase alphabetic characters
Inspection items	Missing characters; printing position; tilted printing; presence/absence of printed characters; missing dots/chipping pixels; decreased print density
Number of characters that can be inspected	Up to 20 characters for each inspection region (up to 2 regions can be set)
Number of images that can be stored	Approx. 10,000 images (for BMP data); approx. 60,000 (For JPEG data)
I/O signals	Input: 10 points; product-type changeover; inspection prohibition; etc. Output: 10 points: OK/NG; in operation; in process; continuous NG; alert; etc.
I/O terminals	USB2.0 x 2; LAN x 2; RS232C x 1
Processing capacity	300 inspections/minute (varies depending on the conditions)
Power supply	AC100-240V±10%; 50/60Hz, 60W
External dimensions	182 mm (W) x 79.6 mm (D) x 157.7 mm (H)
Operating environment	5 - 35°C ; 20 - 80%RH (no condensation)

● Dimensional drawing

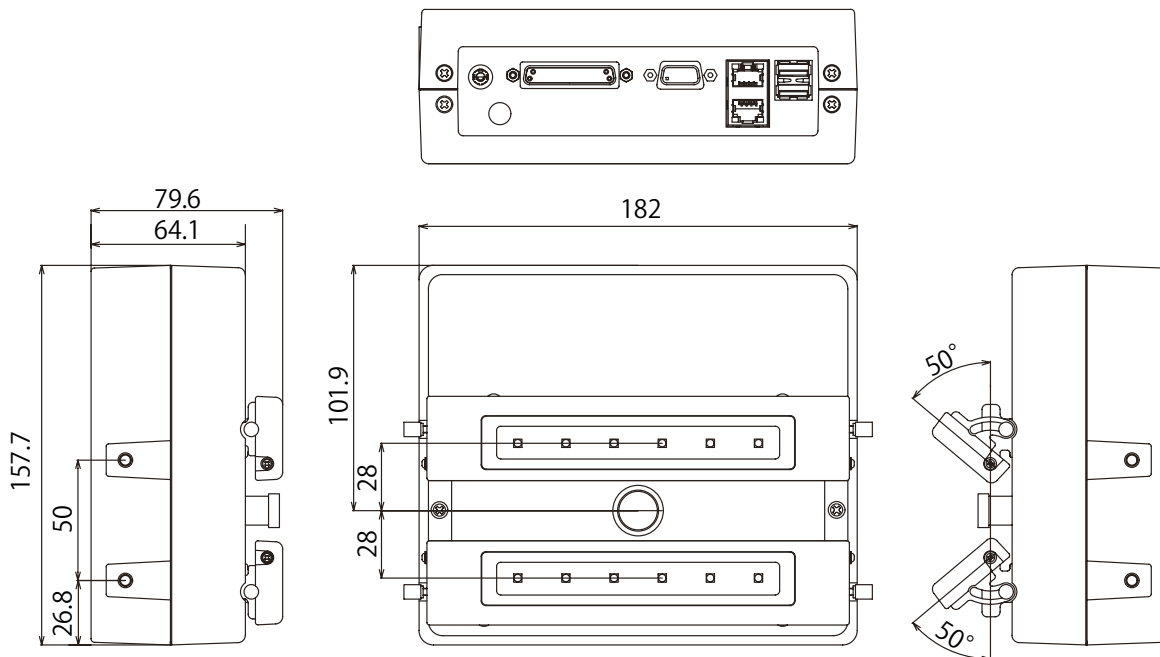

※ Specifications subject to change without notice